



**AGENCY FOR ELECTRONIC COMMUNICATIONS AND
POSTAL SERVICES**

REGULATION

**on the technical and exploitation conditions for use of broadcasting stations for
broadcasting TV programme in VHF I and III and UHF IV and V frequency bands**

Podgorica, April 2010.

Pursuant to Article 8, paragraph 1, item 7 and 19, Article 62, paragraph 2, Article 76 paragraph 1 item 2 and 3 and Article 134 paragraph 1 item 2 of the Law on Electronic Communications ("Official Gazette of Montenegro" No. 50/08 and 70 / 09), Council of the Agency for Electronic Communications and Postal Services at its meeting on 08. 04. 2010th brings

**REGULATION ON THE TECHNICAL AND EXPLOITATION CONDITIONS FOR USE OF
BROADCASTING STATIONS FOR BROADCASTING TV PROGRAMME IN VHF I AND III AND UHF
IV AND V FREQUENCY BANDS**

I General Provisions

(Subject)

Article 1

This regulation defines modes and technical characteristics of radio stations for broadcasting television programs in the VHF frequency bands I and III (47-68 MHz and 174-230 MHz) and UHF IV and V (470-862 MHz) through the analog transmitters and converters for this modes, to ensure the smooth reception of television broadcasts, other radio services and the efficient use of radio frequency spectrum.

(Testing and labeling)

Article 2

Radio stations in Article 1 of these Regulations can only be used if they meet conditions stipulated herein.

The provisions of these Regulations apply to manufacturers and importers of transmitters and converters provided for the modes that are specified by this ordinance.

For all radio stations in Article 1 of these Regulations, it is necessary to test compliance with reference standards and CE mark labeling in accordance with Directive 1999/5/EC of the European Parliament and the Council of Europe (Directive on radio equipment and telecommunications terminal equipment and mutual recognition of their conformity)/regulations on radio equipment and telecommunications terminal equipment.

(The reference international regulations)

Article 3

Reference international guidelines, norms and regulations to be met by broadcasting stations referred to in Article 1 of these Regulations are:

- CCIR Report 624-4 - "Characteristics of Television Systems"
- TU-R Recommendation BT.470-7 - "Conventional analogue television systems"
- ITU-R Recommendation BT.1439-1 - "Measurement methods applicable in the analogue television studio and the overall analogue television system"
- ITU-T Recommendation J.61 including Amd.1 - "Transmission performance of television circuits designed for use in international connections"
- ETSI EN 302 297:2006 - Electromagnetic Compatibility and Radio Spectrum Matters (ERM); Transmitting Equipment for the Analogue Television Broadcasting Service, Part 2: Harmonized EN Under Article 3.2 of the R & TTE Directive
- EN 60244-1:2000 - Methods of measurement for radio transmitters - Part 1: General characteristics for broadcast transmitters "EN 60244-5:1995 - Methods of measurement for radio transmitters - Part 5: Performance characteristics of television transmitters"
- EN 60244-9:1995 - Methods of measurement for radio transmitters - Part 9: Performance characteristics for television transposers "
- EN 60244-10:1993 - Methods of measurement for radio transmitters - Part 10: Methods of measurement for television transmitters and transposers employing insertion test signals.

(Definitions)

Article 4

Terms used herein shall have the following meanings:

1. **TV transmitter:**
 - Amplitude modulated transmitter for a picture with a partially suppressed sideband;
 - Frequency modulated sound transmitter. If there is a crossover, it is considered an integral part of television transmitters.
2. **TV converter:** Common group of circuits (input amplifiers, oscillators, mixers, IF amplifiers, output amplifier, control circuits and other circuits) by which the television signal is received at one, and transmitted on a different channel.
3. **Normal displacement mode (normal offset):** displacement at which the difference between the nominal image frequency carriers is the integer product of half the line frequency, with carrier frequency accuracy within 500 Hz.
4. **Precision frequency displacement (precision offset):** frequency displacement at which the difference between the nominal carrier frequencies is integer product of the 1/12 line frequency, where the accuracy of carrier frequency is 1 Hz.
5. **Transmitter power:** The effective radiated power of carrier during the sync impulses, while the sound transmitting power is the power value of carrier that is not modulated.
6. **TV image:** Image produced by electron-beam on the luminescent curtain of the device for synthesis during the full cycle of the image. The image is composed of two consecutive half of the image.
7. **Analysis with space:** The procedure of image analysis in which the analysis is first done by odd, and then the by even lines.
8. **Half of the image:** The part that is printed between two vertical sync pulses.
9. **Luminance signal (illumination) (E_v):** A signal that uniquely characterizes the brightness (illumination) of image.
10. **Chrominance signal:** A signal that is added to the luminance signal signal in order to get information about the color of an image.
11. **Pilot chrominance carrier:** Extra carrier, that is modulated to give a color signal, located in the frequency range occupied by video signal.
12. **Horizontal suppression impulse:** Additional signal, in general form a rectangular, which lets the electron beam to jump from one line to another.
13. **Vertical suppression impulse:** Additional signal, in general form a rectangular, which lets the electron beam to jump from one half to another half of the image.
14. **Sync pulses:** Additional signals that ensure synchronism of turning the electron beam for analysis and synthesis of image and the reference carrier for demodulation of color signal in the case of color TV sets.
15. **Horizontal sync pulse:** rectangular pulse synchronization that ensures horizontal synchronization of turning electron beam for analysis and synthesis, and is transmitted during the horizontal suppression impulse interval.
16. **Vertical sync pulse:** A signal synchronization composed of one or more rectangular pulses which provide vertical synchronization of turning electron beam for analysis and synthesis, and that is transmitted during the vertical suppression impulse interval.
17. **Reference color signal (burst):** color synchronization signal that consists of several sinusoids at a frequency of the auxiliary carrier, which is transmitted during the horizontal suppression pulse interval.
18. **Equalizing pulses:** Additional signals used in the analysis with spacing during the vertical suppression impulse interval in order to provide spacing during synthesis.
19. **Video signal:** A signal that contains all the signals required for the synthesis of an image: brightness signal, pulses for suppression, synchronization signal, and so on.
20. **Black level:** The level of image signal or video signals corresponding to the minimum brightness signal amplitude. This level corresponds to a point whose brightness is zero, i.e. objects black point.
21. **White level:** The level of image signals or video signals which corresponds to the maximum

amplitude of the brightness signal.

22. **The level of suppression:** The level of image signals or video signals during the suppression pulse, with the exception of levels of various other signals that can be transferred at this time.
23. **The level of synchronization:** The minimum level of video signals corresponding to the horizontal or vertical sync pulses.
24. **Line (horizontal frequency):** Number of lines per second, during the analysis or synthesis of television pictures.
25. **Chrominance difference signals:** The signals that contains only information about the color after being substracted information about the illumination.
26. **Artificial antenna:** Shielded burden that is connected to the transmitter in order to evaluate and replace the actual antenna.
27. **Parasitic oscillations:** The oscillations with a frequency outside the bandwidth, and whose levels can be reduced without affecting the transmission of useful information.
28. **Quadrature amplitude modulation (QAM):** modulation procedure in which the carrier separates into two components with a phase shift to each other of 90° - (quadrature phase shift). One component is modulated by chrominance difference signal $E'_U = E'_R - E'_V$, whereas the second, 90° rotated phase, by chrominance difference signal $E'_V = E'_B - E'_V$. In the PAL television system phase shift of the carrier component, modulated by the signal $E'_U = E'_R - E'_V$, changes sign after each line from $+90^\circ$ to -90° , then again 90° , -90° and so on.
29. **Accentuation:** The process of highlighting the high sound frequencies of modulating signal by increasing of their level prior to modulation.
30. **De-accentuation:** The procedure is an inverse process of accentuation, that is performed after demodulation by lowering amplitude levels of higher frequencies of transmitted signal, providing the improvement of the signal/noise ratio by 10 dB during the frequency modulation with both of these procedures.
31. **Color coordinates:** Rule in the system of the CIE (1931. year) where each of the primary colors are corresponding to one coordinate of the triangle (red, blue, green).
32. **Group delay:** group delay is expressed as the differential ratio of phase and frequency:

$$\tau_g = \frac{1}{2\pi} \frac{d\varphi}{df}$$

Constant value of group delay allows the transfer of components of a complex television signal at the same speed so that at the other end of the transmission system components with identical phases within the limits of tolerance are obtained.

33. **Differential gain:** Different gain at different levels of brightness.
34. **Differential phase:** The phase difference in position at different levels of brightness.

Abbreviations:

PAL - Phase Alternating Line

AF - Audio Frequency

VF - Video frequency

MF - intermediate frequency

RF - Radio frequency

AGC - Automatic Gain Control

TV - Television, in conjunction with television

CIE - Commission Internationale d'Eclairage - International Commission for the lighting

II Frequency ranges and channels

Article 5

Frequency bands allocated for analogue terrestrial television broadcasting systems in the VHF and UHF band, under the Plan of radio frequencies allocation are:

	Frequency band		Channels	TV standard
VHF	I	47-68 MHz	2,3,4	B/PAL
VHF	III	174- 230 MHz	5,6,...,11,12	B/PAL
UHF	IV/V	470-860 MHz	21.....69	G/PAL

TABLE 1 - Frequency ranges intended for analogue terrestrial television broadcasting systems in the VHF I and III and UHF IV and V bands

Article 6

Division of channels per location shall be in accordance with provisions of international agreement as stipulated in Final Act of the European VHF/UHF Broadcasting Conference, Stockholm 1961 (ST61), revision of this Agreement from 2006 (RRC-06-Rev.ST61), and Plan allocation of broadcasting frequencies in Montenegro.

To reduce co-channel noise, the basic picture and sound transmitters must work with the normal frequency offset.

Article 7

Television transmitters must operate with precision frequency offset on the same channel if there are mutual interference within the coverage as a result of deviations from planned values of intensity of electromagnetic fields.

TV converters must work with normal frequency offset on the same frequency channel if anticipating problems in the service area as a result of deviations from planned values of intensity of electromagnetic fields.

Legal and natural persons whose approval was granted, in the case of interference from paragraphs 1 and 2 above, shall agree to modify frequency, with the consent of the Agency, in order to eliminate interference.

III Technical characteristics of television system

Article 8

For television in the frequency ranges VHF I and III is used the PAL system, TV standards B, and in UHF frequency bands IV and V, the standard G. These norms are defined in the recommendation under Article 3, paragraph 1, line 2 of the Regulation.

Basic characteristics of PAL system for standards B and G are given in Table 2 and Figure 1:

Item	Characteristics	B/PAL & G/PAL
1.	Total number of lines per picture (frame)	625
2.	Field frequency, (field/second) f_v	50
3.	Line frequency f_H (Hz)	15 625
	Line frequency f_H (Hz) tolerance when operated non-synchronously	Black and white Color
4.	Blanking level-reference	0
	Peak white level	100
	Synchronizing level	- 43
	Difference between black and blanking level	0
	Peak level including chrominance signal	133
5.	Assumed gamma of display device for which pre-correction of monochrom signale is made	2,8
6	Interlace ratio	2:1
	Aspect ratio	4:3
	Scanning sequence	From left to right
	Scanning sequence	From top to bottom

TABLE 1 – basic characteristics of PAL B and G video signals

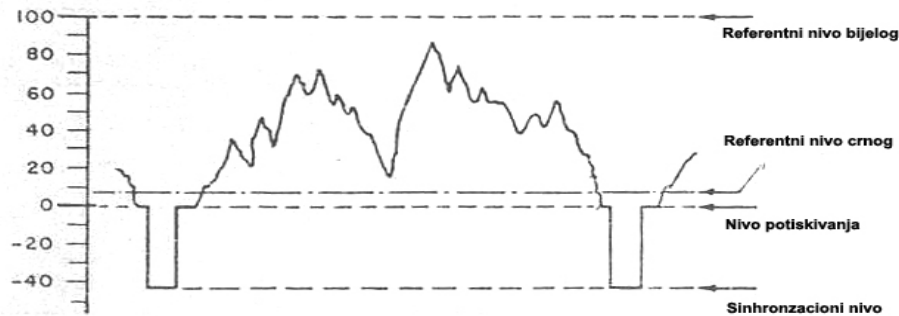

FIGURE 1: TV signal levels

Article 9

Characteristics of horizontal sync signals are given in Table 3 and Figure 2:

Symbol	Characteristic	B/PAL and G/PAL
H	Nominal line period (μs)	65
a	Line-blanking interval (μs)	$12 \pm 0,3$
b	Interval between time datum (O_H) and back edge of line-blanking pulse (μs)	10,5
c	Front porch (μs)	$1,5 \pm 0,3$
d	Synchronizing pulse (μs)	$4,7 \pm 0,2$
e	Build-up time (10 do 90 %) of the edges of the line-blanking pulse (μs)	$0,3 \pm 0,1$
f	Build-up time (10 do 90 %) of the edges of the line-bsynchronizing pulses (μs)	$0,2 \pm 0,1$

TABLE 2 – Details of line synchronizing signals

The values in this table are measured between points at the half amplitude of the corresponding pulse edges.

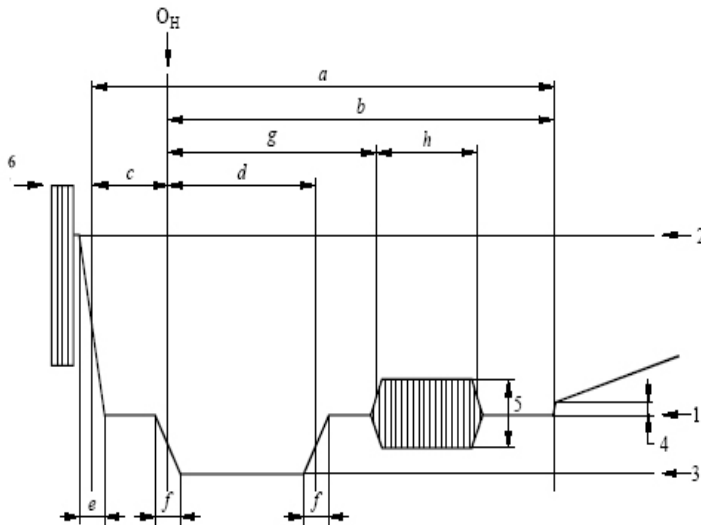

FIGURE 2: Levels in the composite signal and details of line-synchronizing

- | | | | |
|---|---------------------|---|--|
| 1 | blanking level | 4 | difference between black and blanking levels |
| 2 | peak white-level | 5 | peak-to-peak value of burst |
| 3 | synchronizing level | 6 | peak-to-peak value of colour sub-carrier |
| | | 7 | peak level including chrominance signal |

Article 10

Characteristics of vertical sync signals are given in Table 4 and Figures 3 and 4:

Symbol	Characteristic	625 PAL
V	Field period	20 ms
i	Field-blanking interval (for H and a , see Table 3)	$25H + a$
j	Rise time (10 to 90%) of the edges of field-blanking pulses (μs)	$0,3 \pm 0,1$
l	Interval between front edge of field-blanking interval and front edge of first equalizing pulse	$3 \ominus 2 \ominus \text{s}$
m	Duration of first sequence of equalizing pulses	$2,5 H$
n	Duration of sequence of synchronizing pulses	$2,5 H$
p	Duration of second sequence of equalizing pulses	$2,5 H$
q	Duration of equalizing pulse	$2,35 \ominus 0,1 \ominus \text{s}$
r	Duration of vertical field-synchronizing pulse (μs)	27,3
s	Interval between field-synchronizing pulse	$4,7 \ominus 0,2 \ominus \text{s}$
s	Rise time (10 to 90%) of synchronizing and equalizing pulses (μs)	$0,2 \pm 0,1$

TABLE 4 – Details of vertical field synchronizing signals

Lines 16 and 22, or 329 to 334 during suppression pulses interval may be used for special purposes, such as the transmission of test signals and so on.

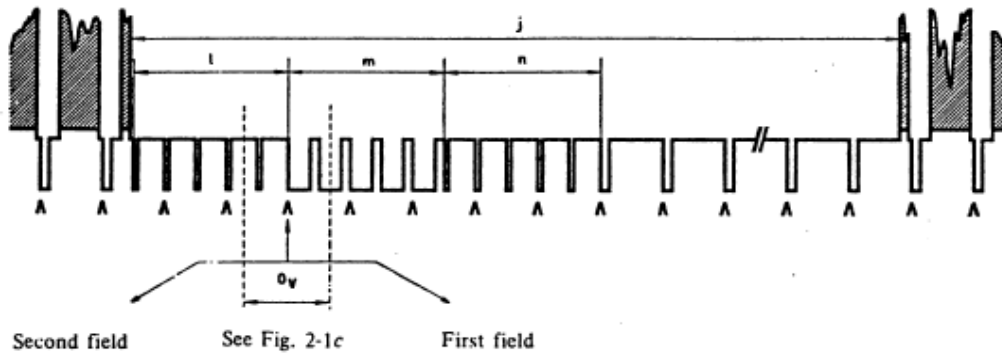

FIGURE 2-1a - Signal at beginning of each first field

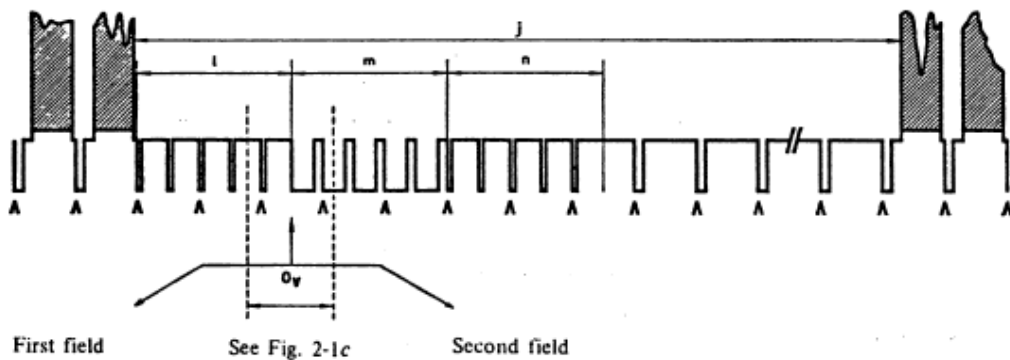
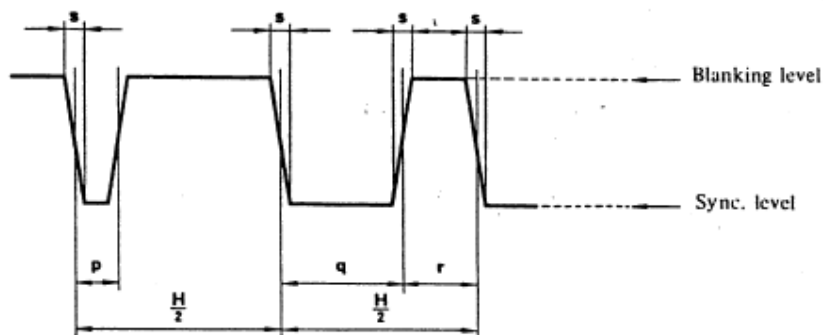

FIGURE 3: Details of field-synchronizing

Note 1. - $\wedge \wedge \wedge$ indicates an unbroken sequence of edges of line-synchronizing pulses throughout the field-blanking period.

Note 2. - At the beginning of each first field, the edge of the field-synchronizing pulse, O_v , coincides with the edge of a line-synchronizing pulse if l is an odd number of half-line periods as shown.

Note 3. - At the beginning of each second field, the edge of the field-synchronizing pulse, O_v , falls midway between the edges of two line-synchronizing pulses if l is an odd number of half-line periods as shown.



(The durations are measured between the half-amplitude points on the appropriate edges)

FIGURE 4: Details of equalizing and synchronizing pulses

Article 11

Characteristics of video signal (PAL system) are given in Table 5 and Figures 5 and 6:

Item	Characteristic	B/PAL i G/PAL								
			x	y						
1	Assumed chromaticity coordinates (CIE, 1931) for primary colours of receiver ⁽¹⁾	Red	0.64	0.33						
		Green	0.29	0.60						
		Blue	0.15	0.06						
		Illuminant D65	0.313	0.329						
2	Chromaticity coordinates for equal primary signals $E'_R = E'_G = E'_B$ (reference white)	Illuminant D65	0.313	0.329						
3	Luminance signal	$E'_Y = 0.299 E'_R + 0.587 E'_G + 0.114 E'_B$ E'_R, E'_G and E'_B are gamma-pre-corrected primary signals								
4	Chrominance signals (colour difference) matrix equations	$E'_U = 0.493 (E'_B - E'_Y)$ $E'_V = 0.877 (E'_R - E'_Y)$								
5	Attenuation of colour difference signals	$E'_U < 3$ dB at 1.3 MHz $E'_V > 20$ dB at 4 MHz								
6	Equation of composite colour signal	$E_M = E'_Y + E'_U \sin(2\pi f_{sc} t) + E'_V \cos(2\pi f_{sc} t)$ Where: E'_Y see item 3 of the Table, E'_U and E'_V see item 4 of the Table. f_{sc} see item 8 of the Table. The sign of the E'_Y component is the same as that of the sub-carrier burst (changing for each line) (see item 13 of the Table and Picture 5)								
7	Type of chrominance sub-carrier modulation	Suppressed-carrier amplitude-modulation of two sub-carriers in quadrature (QAM)								
8	A. Chrominance sub-carrier frequency (Hz) Deviation (Hz)	$f_{sc} = 4\,433\,618.75$ ± 5								
	B. Relationship between chrominance sub-carrier frequency f_{sc} and line frequency f_H	$f_{sc} = \left(\frac{1135}{4} + \frac{1}{625}\right) f_H$ $f_{sc} = 567.5 + f_H / 2$								
9	Bandwidth of chrominance sidebands (kHz)	f_{sc}	+ 570	- 1 300						
10	Amplitude of chrominance sub-carrier	$\sqrt{E'^2_U + E'^2_V}$								
11	Synchronization of chrominance sub-carrier	Sub-carrier burst on blanking back porch								
	A. Start of sub-carrier burst (μ s) See Fig 2. B. Duration of sub-carrier burst (μ s) See Fig 2.	5,6 \pm 0,1 after epoch Oh 2,25 \pm 0,23 (10 \pm 1 cycles)								
12	Peak to peak value of chrominance sub-carrier burst	3/7 of difference between blanking level & peak white-level \pm 10 %								
13	Phase of chrominance sub-carrier burst (see Fig. 6)	135° relative to E'_U axis with the following polarity								
		Line	1	2	3	4	5	6	7	8
		Burst blanking sequence	I	II	III	IV	I	II	III	IV
		Even line	-	-	+	+	-	-	+	+
Odd line	+	+	-	-	+	+	-	-		
14	Blanking and chrominance sub-carrier	9 lines of the field-blanking intervals:								
		Lines:	311 to 319 inclusive (IV)							
			623 to 6 inclusive (I)							
			310 to 318 inclusive (II)							
	622 to 5 inclusive (III)									
15	Synchronization of chrominance sub-carrier switching during line blanking	By E_V chrominance component of sub-carrier burst (See Fig 6. and item13.)								

TABLE 3 – Characteristics of PAL video signal

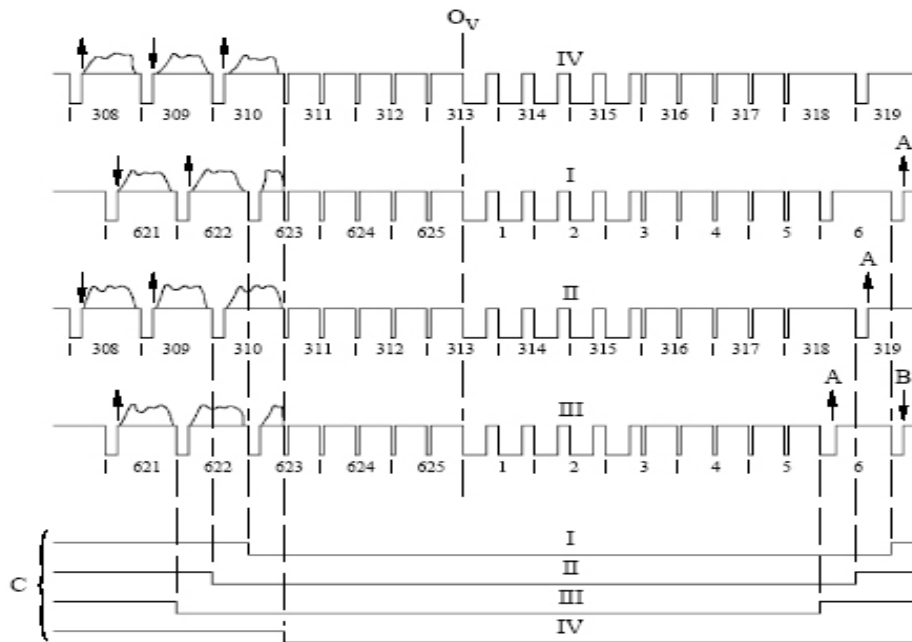

FIGURE 5 Burst-blanking sequence 625 PAL

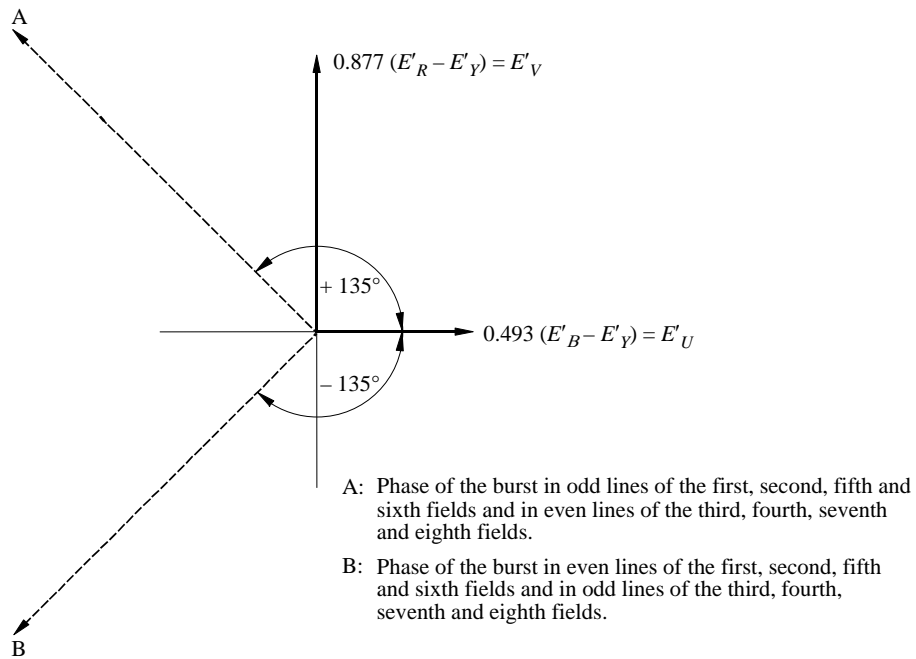

FIGURE 6 Phase of the sub-carrier synchronization burst

Article 12

Radio-frequency characteristics of the system B and G are given in Table 6 and Figure 7:

Item	Characteristics	B/PAL i G/PAL	
1	Nominal radio-frequency channel bandwidth (MHz)	B: 7 G: 8	
2	Sound carrier relativ to vision carrier (MHz)	+ 5,5 ±0,001	
3	Nearest edge of channel relative to vision carrier (MHz)	- 1,25	
4	Nominal width of main sideband (MHz)	5	
5	Nnominal width of vestigial sideband (MHz)	0,75	
6	Minimum attenuation of vestigial sideband (dB at MHz)	dB	MHz
		20	- 1,25
		20	- 3,0
		20	- 4,43
7	Type and polarity of vision modulation (emision)	C3F neg.	
8	Levels in radiated signal (% of peak carrier)		
	Synchronizin level	100	
	Blanking lebel	75 ± 2,5	
	Difference between black level and blanking level	0 - 2	
	Peak white-level	10 – 15	
9	Type of sound modulation	F3E	
10	Frequency deviation (kHz)	± 50	
11	Pre-emphasis for modulation (µs)	50	
12	Ratio of effective radiated powers of vision and sound	20/1 – 10/1	
13	Pre-correction for receiver group-delay characteristics at medium video frequency	See Fig 7.	
14	Pre-correction for receiver group-delay characteristics at colour sub-carrier frequency (ns)	- 170	

TABLE 4 – Radio-frequency characteristics of PAL B and G signals

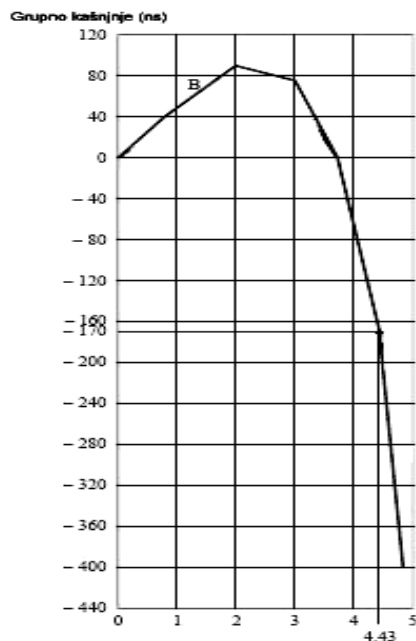

Frekuensi (MHz)	Group delay (ns)
0,25	+5 ± 0
1,0	+53 ± 40
2,0	+90 ± 40
3,0	+ 75 ± 40
3,75	0 ± 40
4,43	-170 ± 40
4,80	-400 ± 90

FIGURE 5: Group delay

IV Technical characteristics of television transmitters

Article 13

Television transmitter shall be so constructed as to meet the following general technical requirements:

1. Transfer System

The transmitter must allow the transmission system defined in Articles 8, 9, 10 and 11 of the Regulation.

2. Class of emission

The transmitter is used for class of emission C3F for image and F3EGN for tone.

3. Frequency range

The boundaries of frequency bands in which the transmitter can be configured to work are given in Article 5 of the Regulations. The transmitter can be designed so that it can cover the whole or part of these frequency bands.

Mark at each transmitter must specify the exact part of the band or frequency range for which the transmitter is provided.

The transmitter shall be so constructed as to enable adjustment of each channel in the frequency band for which is provided.

4. The maximum carrier frequency error

The maximum error of image and sound carrier frequencies for various frequency bands and rated output powers of the transmitter must be within the tolerance given in Table 7

Frequency band (MHz)	Rated output power P_P (W)	Frequency tolerance (Hz)
47 – 68	$P_P \leq 50$	± 2000
	$P_P > 50$	± 500
174 – 230	$P_P \leq 1$	± 5000
	$1 < P_P \leq 100$	± 2000
	$P_P > 100$	± 500
470 – 862	$P_P \leq 1$	± 10000
	$1 < P_P \leq 100$	± 2000
	$P_P > 100$	± 500

TABLE 5 - The maximum error of image and sound carrier frequencies

If the transmitter is designed to work with a specific frequency offset, the maximum image carrier frequency, regardless of the frequency range and rated output power, must be within certain tolerance:

- ± 500 Hz - for transmitters with normal frequency offset;
- ± 1 Hz - for transmitters with precise frequency offset.

5. Carrier frequency stability

Short-term frequency stability of sound and image carrier, for a period of 1 h, must be in accordance with specified manufacturer's technical instructions. Long-term frequency stability of sound and image carrier, for a period of six months, must be greater than the value given in Table 8

Frequency band (MHz)	Rated output power P_P (W)	Frequency stability (Hz)
47 – 68	$P_P \leq 50$	± 1000
	$P_P > 50$	± 250
174 – 230	$P_P \leq 1$	± 2500
	$1 < P_P \leq 100$	± 1000
	$P_P > 100$	± 250
470 – 862	$P_P \leq 1$	± 5000
	$1 < P_P \leq 100$	± 1000
	$P_P > 100$	± 250

Tabela 6 - Long-term frequency stability of sound and image carrier

If the transmitter is designed to work with a specific frequency offset, the maximum frequency of image carrier, regardless of the frequency range and the rated output power, must be within certain tolerance:

- a. ± 250 Hz - for transmitters with normal frequency offset;
- b. ± 0.5 Hz - for transmitters with precise frequency offset.

6. Accuracy of frequency setting

Accuracy of setting of transmitters frequency carrier with normal frequency offset must be better than ± 50 Hz.

7. Transmitters intermediate frequencies

Transmitters intermediate frequencies are:

- a. 38.9 MHz - for image channel;
- b. 33.4 MHz - for sound channel.

8. Rated output power

Nominal transmitter output power in the channel of the image must be primarily one of the following values: 0.5 W, 1 W, 2 W, 5 W, 10 W, 20 W, 50 W, 100 W, 200 W, 250 W, 500 W, 1 kW, 2 kW, 5 kW, 10 kW, 20 kW or 50 kW.

Nominal transmitter output power in the channel of the image must be specified in the technical instructions on the manufacturer.

9. Deviation of output power

At the rated voltage of the primary power source, transmitter output power may deviate from its nominal value by a maximum of:

- a. 0 and 10% - the measurement in production and trade;
- b. +10% and -20% - the measurement of the use and maintenance;
- c. When changing voltage power supply from Section 21 of this article, the deviation of output power must be indicated in the technical manual.

10. Rated output load impedance

Rated output load impedance of a transmitter is 50 Ω (unbalanced).

11. Voltage standing wave ratio (VSWR) of output load

The transmitter, at the entrance of the output load, has to work with established characteristics of the VSWR less or equal to 1.05.

Maximum VSWR at which the transmitter can operate without damage or without the operation of protective devices is 1.4.

12. Nominal input impedance

Nominal input impedance of the transmitter in the channel of the image must be 75 Ω asymmetrical.

Nominal input impedance of the sound channel must be:

- a. 600 Ω balanced or
- b. ≥ 2000 Ω symmetrical or asymmetrical.

13. Return loss at the entrance

Return loss at the entrance to the transmitter image channel in the video-frequency range must be greater than 30 dB.

Return loss at the entrance to the transmitter sound channel in the audio-frequency range must be greater than 25 dB.

14. Rated input voltages

Rated input voltages of the transmitter are:

- a. $V_{VV} 1$ - for video-frequency signal between the level of synchronization pulse and the level of white so that:
 - the level of synchronization pulse is 0%;
 - the level of black is 30%;
 - the level of white is 100%;
- b. 1.55 V – for audio - frequency sinusoidal signal, at 1 kHz frequency, which causes deviation of the frequency of ± 50 kHz.

15. Input voltage range

Input video-frequency voltage range in relation to the rated input voltage, at which the transmitter must be adjusted to meet the identified characteristics, must be ± 3 dB.

Input audio-frequency voltage range in relation to the rated input voltage, at which the transmitter must be adjusted to meet the identified characteristics, must be ± 6 dB.

16. Secondary components

The mean power of any secondary components at the antenna cable connector, for different frequency ranges, and transmitter mean power shall not exceed maximum levels set out in Table 9

Frequency range (MHz)	Mean Power P_m (W)	The maximum power level of secondary components	
		mW	dB vs P_m
47 – 68 174 – 230	$P_m \leq 0,25$	0.025	-40
	$0,25 < P_m \leq 25$		-60
	$25 < P_m \leq 1\ 000$		
	$1\ 000 < P_m$	1	
470 – 862	$P_m \leq 0,25$	0,025	-40
	$0,25 < P_m \leq 25$		
	$25 < P_m \leq 20\ 000$	20	-60
	$20\ 000 < P_m$		

TABLE 8 - Maximum permitted levels of transmitter and secondary components mean power

17. Radiation of transmitter case

When the transmitter is connected to an artificial load that does not radiate, the ERP of the transmitter case must not exceed:

- a. Limit values for the power of secondary compounds from Item 16. of this article;
- b. 1 W at a frequency of core components, for the rated transmitter power output from 1 kW to 10 kW;
- c. 10 W at a frequency of the basic components for the rated transmitter power output equal to or greater than 10 kW.

Television transmitter must be electrically shielded so that in case of bigger number of transmitter next to each other mutual interference does not occur.

18. Environmental conditions

- Ambient temperature

Transmitter together with the auxiliary devices must:

- a. work with established features at an ambient temperature of $+5^{\circ}$ C to $+35^{\circ}$ C, and for the transmitters of less than 100 watts, from 5° C to 45° C;
- b. to continue to work without danger or damage at an ambient temperature of $+5^{\circ}$ C to $+45^{\circ}$ C;
- c. as the coverted assistive devices can be considered heat exchangers, cooling systems, etc..

- Relative humidity

The maximum value of relative humidity at which the transmitter operates with the defined characteristics, or is turned off for some time, without damaging the parts, is 90% at a temperature of 26° C.

- Temperature and humidity of inlet air cooling

Limit temperature and relative humidity of inlet air for cooling of air-cooled transmitter must be such as to satisfy conditions for ambient temperature and relative humidity and must be determined by the

manufacturer.

- Elevation

The transmitter has to work with established features at an altitude of 2000 m.

In the technical manual must be stated the conditions for the operation of coverter at altitudes greater than 2,000 m.

19. Warm-up Time

Warm-up time of transmitter needed to achieve the set features must not exceed 30 minutes.

20. Type of power source

Power source of transmitter is:

- a. Single phase or three phase – for the transmitter with rated output up to 1 kW;
- b. Three-phase - for the transmitter with rated output greater than 1 kW,

Three-phase source must have a neutral conductor and equal phase distribution of load and must be noted that the neutral wire is grounded or not.

21. Voltage and frequency of power supply

Voltage and frequency of power supply at which the transmitter shall work with established characteristics are:

- a. Rated power supply voltage value and deviations from these values are:
 $220 V_{-15\%}^{+10\%}$ for DC power,
 $380/220 V_{-15\%}^{+10\%}$ for the three-phase AC power.
- b. Deviation waveform
Deviation waveform must not be greater than 5%.
- c. The asymmetry in the three-phase voltage
In the three-phase power supply must be given the value of the allowed voltage asymmetry by applicable standards and regulations.
- d. Rated power supply frequency value and maximum deviation
Rated value of frequency of alternate power sources and the maximum deviation of these values are $50 \pm 1\text{Hz}$.

22. Active power supply (consumption)

Active power supply (consumption) of transmitters, including assistive devices, during the modulation with black and white picture and at the rated output power, must be indicated in the manufacturer's technical instructions.

23. The total power factor of power supply

The total power factor of power supply in terms of paragraph 22 of this article must be ≥ 0.9 .

24. Additional provisions relating to the supply network

The following information must be stated :

- a. Disturbances voltages in power network due to transmitter operation;
- b. Immunity to transients in the supply network;
- c. Peak supply current while switching devices.

25. Security measures

The measures taken by the transmitter and auxiliary equipment to protect staff from accidents must be stated. These measures must be in accordance with standards and regulations that are valid in Montenegro.

26. Lightning Protection

In the technical manual must be indicated the procedure for the transmitter lightning protection.

The chosen method of protection shall be in accordance with applicable standards and regulations.

27. Endurance

The transmitter has to endure 24 hours of continuous operation with the indicated strength in the modulation of the black image and the arbitrary modulation of sound, in terms of points 18, 21 and 23 of this article.

28. Work in error

In case of disappearance of input signal or other errors on it, the transmitter shall automatically continue to operate without damage when the input signal again appears or the error disappears.

29. Radiated heat

Radiated heat of the transmitter in the labor room at the worst conditions should be indicated in the technical manual.

30. Protection systems

Overload protection device must turn off device (or part of it) if an error exists, and after two or three attempts to establish the initial state. Protective device must take action only when overload can cause damage, and in time to prevent damage.

31. The operational stability

The transmitter shall not require continuous monitoring to continually work with the established characteristics. This requirement meets over the preventive maintenance in accordance with technical manual.

32. The reliability of the transmitter

The reliability of the transmitter must be such that the mean time between interruptions shall not be less than 1,500 h.

33. Management and Supervision

Commands and indicators for the device monitoring and techniques used for interconnection of transmitter and systems for monitoring, shall be given in a technical manual.

34. Test points

- **Radio-frequency points of the image channel**

On the image channel of a television transmitter must be provided radio frequency test points for:

- a. IF output level;
- b. parts of the transmitter operating at the extreme frequency whose strength is greater than 200W;
- c. output of the transmitter output;
- d. switch output.

At the transmitters measuring points with rated power output exceeding 100 W and protective resistor of 50 Ω radio-frequency voltage must be 1 V.

At the transmitter output must be directive coupler with a characteristic impedance of 50 Ω , orientation of 32 dB, for transmitters with power exceeding 100 W, and the loop that will ensure the completion of the radio frequency voltage effective value of 1V at direct output resistor of 50 Ω .

- **Radio-frequency points for the measurement of sound channel**

At the transmitter output stage for sound channel must be test point.

Radio-frequency test point shall have a BNC connector type.

For transmitters with output power of less than 100 watts, this provision does not apply.

- **Video-frequency test points**

At the image channel of a television transmitter must be provided video-frequency test points for:

- a. Video-frequency input;
- b. Modulator input;
- c. At the measuring points completed with a 75 Ω resistor shall be a positive video voltage of 1 V_{VV};
- d. Deviation of the amplitude/video frequency characteristics of the measuring points from the set value can not be greater than ± 0.5 dB.

All Video-frequency test points must have a BNC type connectors.

35. Indicators

Sound channel of the television transmitters must have indicators for:

- Output power;
- Reflected power;
- Frequency deviation.

For transmitters with output power of less than 100 W indicators for reflected power and frequency deviation are not mandatory.

36. External excitation

For external excitation, instead of the basic oscillator, must be provided access to the input impedance of 50 Ω. Excitation of the transmitter should be possible with a voltage whose value is not greater than 1 V. The transmitter must indicate the main oscillator frequency channels.

37. Impedance of high frequency stage

All stages and conductors at the high frequency part must be reduced to a nominal impedance of 50 Ω.

38. Artificial antenna

Television transmitter measurements requires an artificial antenna.

Rated resistance value of artificial antenna is 50 Ω.

In the frequency range of the transmitter the non-adjustment ratio must be less than 1.05.

Modification of non-adjustment coefficient with frequency in the working channel must be less than 0.02.

Artificial antenna resistance value is given from the fifth harmonic frequency transmitter but not more than 2 GHz.

39. Measures

Dimensions (width, height and depth) of a transmitter must be in line with technical manual.

40. Mass

The mass of the transmitter must be in line with technical manual.

Article 14

Special features for image transmission are:

1. The amplitude/radio-frequency characteristic

The amplitude/radio-frequency characteristic must be within the limits of the figure 8

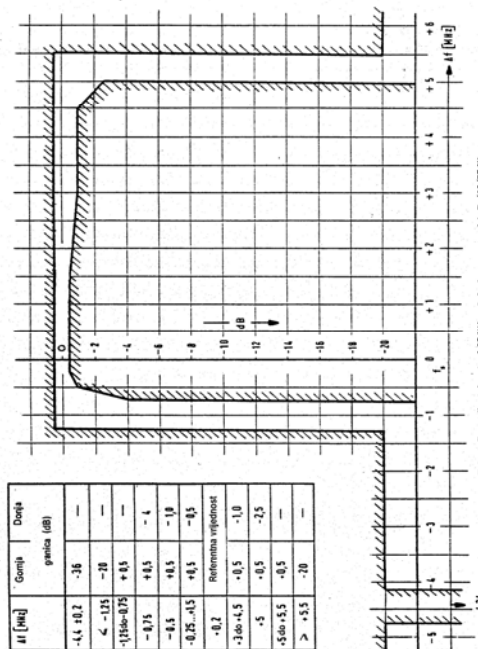

Figure 8: The characteristic of amplitude / frequency of radio transmitter

2. The amplitude/video-frequency characteristic

The amplitude/video-frequency characteristic has to be within the limits of the figure 9.

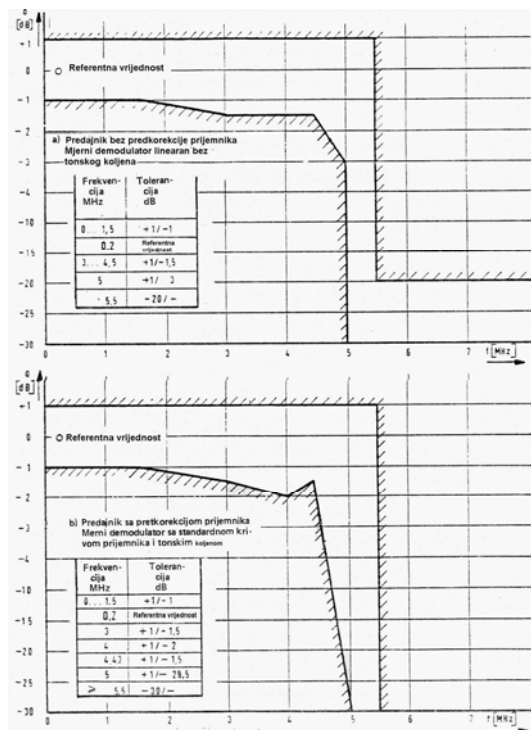

Figure 9: The characteristic of amplitude/video-frequency.

3. The characteristic of group delay/radio-frequency

The characteristic of group delay/radio-frequency must be within the limits of the Figure 10

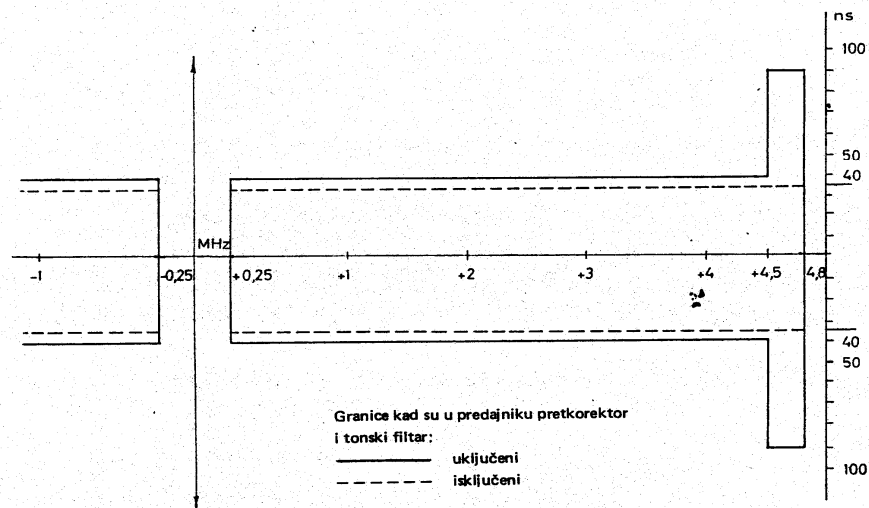

Figure 10: The characteristic of group delay/radio-frequency

The transmitter must have device for receiver pre-correction of group delay and correction of group delay of transmitter. It must be possible to turn off the device for receiver pre-correction.

4. Slope of luminant strip

Slope of luminant strip for the test signal type I must not exceed 2% K.

5. 2T pulse and strip relationship

2T pulse and strip relationship can not be more than 1.5% K.

6. 2T pulse shape distortion

2T pulse shape distortion shall not exceed 2% K.

7. Vertical slope of white field

Vertical slope of white field is the difference between the amplitude of the white field in lasting images measured 250 μ s after the point at the half amplitude of the front edge and 250 μ s before the point at the half amplitude of the rear edge.

Vertical white stripe on slopes shall not exceed 2% K.

8. Variation in output power due to the image content

Variation in output power when changing from black to white images shall not exceed 0.5 dB.

9. Change in the level of suppression

Suppression change due to:

- a. the image content change shall not exceed 1%;
- b. video input signal level of suppression change shall not exceed 1%;
- c. Humming or noise superposed input video signal shall not exceed 1%

10. Luminant nonlinearity

Luminant nonlinearity shall not exceed 10%.

11. Differential gain

Differential gain related to the change in the amplitude of the auxiliary color carrier due to changes in the amplitude of the accompanying light signals must not exceed 3%.

12. Differential phase

Differential phase of reference color carrier shall not exceed:

- a. 3° for VSB demodulator with synchronous demodulation;
- b. 5° for VSB demodulator with envelope detection.

13. Chrominance/luminance mapping

Chrominance/luminance mapping must not be greater than 1.5%.

14. Modulation incidental phase

Modulation incidental phase shall not exceed 30

15. Signal to random noise rate

Signal to random noise rate must be:

- a. Greater than 63 dB (weighted);
- b. Greater than 56 dB (unweighted).

16. Signal to periodic noise rate

Signal to periodic noise rate and other single frequency components must be greater than 43 dB.

17. Intermodulation products

- a. Intermodulation products within the image channel must not exceed the value given in Figure 11

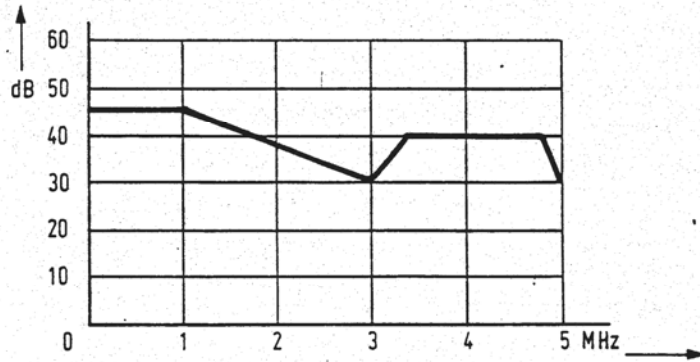

Frequency MHz	S/N dB
0 - 1	46
3	30
3,6 - 4,9	40
5	30

Figure 11: Limits intermodulacionih products within the channel image

- b. Intermodulation products outside the image channel must not be greater than -55 dB.

18. Limit of the level of white

Level of white limiting circuit has to work so that the level of picture carrier does not fall below 7%, while there may not deteriorate luminance nonlinearity.

Article 15

When the input signal from paragraph 14 of Article 13 of the Regulation the output signal levels have to be in line with figure 12.

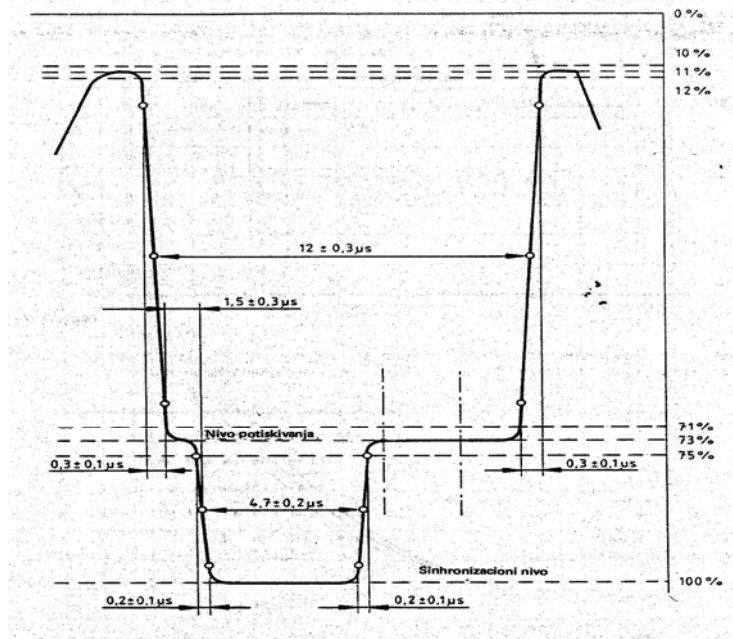

Figure 12: Levels of output signal of channels for the picture

Article 16

Special features of the tone channel are :

1. Maximum frequency deviation

Maximum frequency deviation of the sound channel is ± 50 kHz.

2. The characteristic of amplitude/frequency

The characteristic of amplitude/frequency of the circuits for pre-accentuation has to be within tolerance from the image 13 and Table 10.

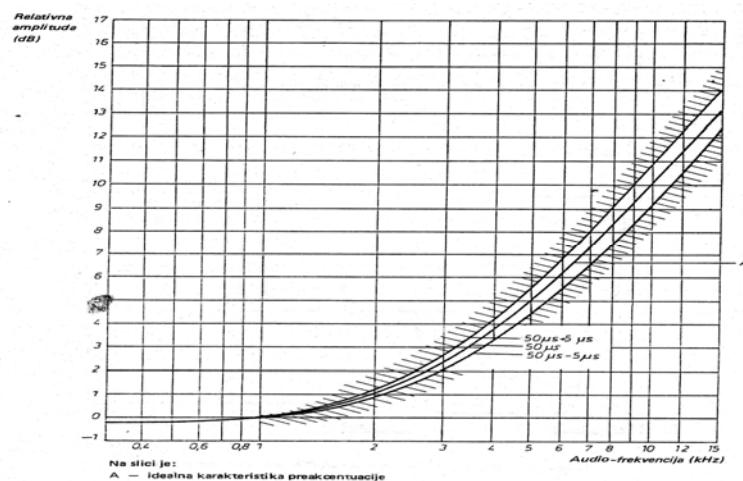

Figure 13: Tolerance for the characteristic of amplitude/frequency of the circuits for pre-accentuation

Frequency (Hz)	Pre-accentuation characteristic in relation to 1 kHz	
	Ideal	Tolerance
30 do 90	- 0,41	
100	- 0,40	
200	- 0,37	
300	- 0,34	
400	- 0,30	
500	- 0,26	
600	- 0,26	
700	- 0,20	
800	- 0,14	
900	- 0,07	
1 000	0	
2 000	+ 1,04	+ 0,17 i - 0,17
3 000	+ 2,35	+ 0,33 i - 0,33
4 000	+ 3,71	+ 0,44 i - 0,46
5 000	+ 4,99	+ 0,52 i - 0,56
6 000	+ 6,17	+ 0,58 i - 0,62
7 000	+ 7,25	+ 0,62 i - 0,67
8 000	+ 8,23	+ 0,64 i - 0,70
9 000	+ 9,13	+ 0,66 i - 0,73
10 000	+ 9,95	+ 0,68 i - 0,75
11 000	+ 10,71	+ 0,69 i - 0,76
12 000	+ 11,41	+ 0,70 i - 0,77
13 000	12,07	+ 0,70 i - 0,78
14 000	12,68	+ 0,71 i - 0,79
15 000	13,25	+ 0,71 i - 0,80

Table 9: Tolerance for the amplitude/frequency characteristic of the circuit for pre-accentuation

3. The amplitude/modulating frequency characteristic

The amplitude/modulating frequency characteristic may not differ more than ± 1 dB from the ideal amplitude/frequency characteristics of the circuits for pre-accentuation, i.e. has to be within the limits specified in Figure 14.

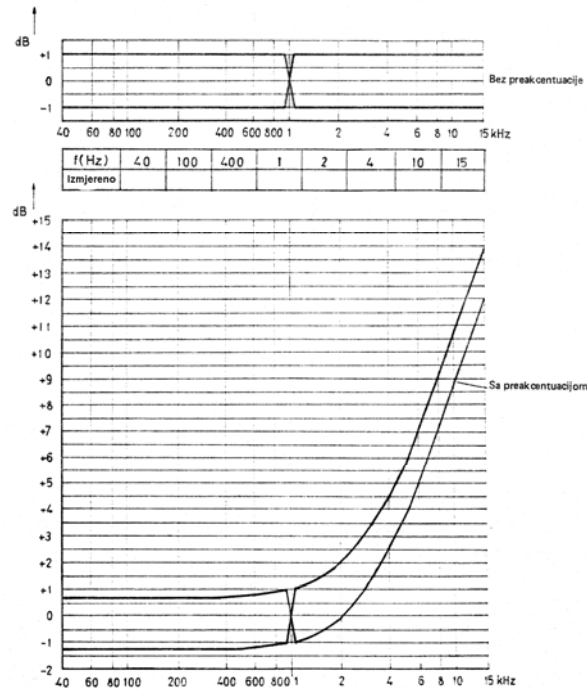

Figure 14: The characteristic of amplitude/frequency modulating

4. AF harmonic distortion

In the resulting modulation due to sinusoidal input signal with any frequency in the range of 40 Hz to 15 kHz AF harmonic distortion:

- must not exceed 0.7% for the frequency deviation ± 50 kHz;
- must not exceed 1.4% for the frequency deviation of ± 70 kHz.

5. AF intermodulation distortion factor

When the modulation due to two sinusoidal tones of constant frequency difference between 71 and 400 Hz, with asymmetric middle of the frequencies in range 700 Hz to 14.8 kHz and with equal levels, AF harmonic distortion factor must be:

- $d_2 \leq 0,35 \%$
 $d_3 \leq 0,5 \%$
 - $d_2 \leq 0,7 \%$
 $d_3 \leq 0,1 \%$
- for the frequency deviation of ± 50 kHz
- for the deviation of frequency from 50 to 70 kHz

6. FM noise and hum level

FM noise and hum level, as measured from the reference level due to the modulation with sinusoidal input signal with a frequency of 1 kHz and with level that gives the frequency deviation of ± 50 kHz, shall not exceed 60 dB.

7. Weighted level of FM noise

Weighted FM noise level measured under the terms of Section 6 shall not exceed - 65 dB.

8. AM noise and hum level

- a. The maximum AM noise and humming level shall not exceed - 46 dB (0.5%).
- b. For transmitters with a common amplification of sound and image carriers, the maximum value of AM noise and hum level shall not exceed -26 dB.

9. The level of synchronous AM modulation

- a. The level of transmitters synchronous amplitude modulation, measured at the modulation resulting due to the sinusoidal input signal with a frequency of 1 kHz and with level that gives the frequency deviation of ± 50 kHz, shall not exceed 40 dB.
- b. For transmitters with a common picture and sound amplification, the level of synchronous AM shall not exceed -26 dB.

10. Changing of the center frequency

In the modulation resulting due to sinusoidal input signal of any frequency within the baseband and with the level that gives maximum frequency deviation ± 50 kHz frequency change shall not exceed 200 Hz.

11. Cross-modulation of image and sound

Cross-modulation of image and sound at transmitters with a common image and sound amplification shall not exceed 2%.

V Characteristics of television converters

Article 17

Integral parts of converters, in terms of the Regulation, are:

- a. Devices for pre-correction and maintenance of required television signal and image stability;
- b. Circuits for obtaining the characteristic with partially transmitted lower sideband;
- c. Circuits for video and audio signal combining;
- d. Harmonic filters or other filters;
- e. Every other utility that is required for normal operation of the converter.

Article 18

Converter must be built to meet the following general specifications:

1. Transmission system

The transmitter must allow the transmission system defined in Articles 8, 9, 10, 11 of the Regulation.

2. Class of emission

The transmitter is used for class of emission C3F for image and F3EGN for sound.

3. Frequency range

Bands border frequencies, in which the inverter can be set to work (receiving and transmitting) are given in Article 5 of the Regulation.

Converter technical manual must state:

- a. combination of receiving and transmitting frequencies that must be avoided and
- b. part to be replaced or added in order to cover the frequency range.

4. The maximum carrier frequency error

The values of these points correspond to the values specified in Article 13, paragraph 4 of this Regulation.

5. Carrier frequency stability

Short-term sound and image carrier frequency stability, for a period of 1 h, must be in accordance with specified in the manufacturer's technical instructions.

Long-term sound and image carrier frequency stability, for a period of six months, must be better than ± 350 Hz

6. Frequency correction

It should be possible to perform frequency correction in an easily accessible and designated place.

7. Intermediate frequency

Converter intermediate frequency is 38.9 MHz, while for the unfavorable combination of channels it may be 45.9 MHz.

Permission is granted for direct frequency conversion while the converter must meet the characteristics set forth herein.

8. Rated output power

Converter rated output power (peak envelope power) primarily must be one of the following values:

- a. 0.05 W, 0.1 W, 0.2 W for miniature television converters;
- b. 0.5 W, 1 W, 2 W, 5 W, 10W, 20W, 25 W, 50 W, 100 W, 200 W, 250 W, 500 W, 1 kW for television converters.

9. Deviation of output power

Fundamental values of these points correspond to the values specified in Article 13, item 9 except for the deviation of the voltage change that must be specified in the technical manual.

10. Rated output load impedance

Rated output load impedance of transmitter is 50 Ω (unbalanced).

All high-frequency degrees must have the same rated impedance of 50 Ω .

11. Voltage standing wave ratio (VSWR) of output load

Converter has to work with established characteristics when at the entrance to the output load VSWR is less or equal to 1.2.

Maximum VSWR at which the converter can operate without damage or without the operation of protective devices is 1.5.

12. Rated input impedance

Rated input impedance must be 50 Ω asymmetrical.

13. Reflection attenuation at the entrance

Reflection attenuation at the entrance to the converter must be greater than 20 dB.

14. Rated input voltage

Rated value of input RF voltage is 2 mV (66 dB μ V).

15. Input voltage range

RF Input voltage relative to the rated input voltage ratio at which the converter must be adjusted to meet the identified characteristics must be within + 14 dB and -12 dB.

16. Minor components

The values of these points correspond to the values specified in Article 13, Item 16 of the Regulation.

17. Transmitter case radiation

When the transmitter is connected to an artificial load that does not radiate, the ERP of the case must not exceed:

- a. Limit values for the strength of secondary components from Section 18 of this article;
- b. 1 W at a frequency of the base component, for the transmitter rated output power up to 1 kW.

18. Environmental conditions

▪ Ambient temperature

Converter with auxiliary devices must:

- a. work with established features at an ambient temperature of +5° C to + 40° C;
- b. continue to work without danger or damage at an ambient temperature of +5° C to + 55° C.

As converters assistive devices can be considered heat exchangers, cooling systems, etc..

▪ **Relative humidity**

The maximum value of relative humidity at which the converter works with established features, or is turned off for some time, without parts damaging, is 90% at a temperature of 27°C.

▪ **Temperature and humidity of inlet air cooling**

Limit temperature and relative humidity of inlet air for air-cooled converters must be such as to satisfy conditions for ambient temperature and relative humidity and must be determined by the manufacturer.

▪ **Elevation**

Converter has to work with established features at an altitude of 2000 m.

The technical manual must state the conditions for operation at altitudes greater than 2000 m.

19. Warm-up Time

Warm-up time of transmitters needed to achieve the set features should not exceed 30 minutes.

20. Type of power source

Converter power source can be alternating (single phase or three phase) or one-way.

21. Voltage and frequency power supply

▪ **Rated power supply**

Rated voltage power supplies and deviations from these values are:

- a. $220 V_{-30\%}^{+10\%}$ for one-way power;
- b. $380/220 V_{-30\%}^{+10\%}$ for the three-phase power;
- c. 12 V, 24 V, 36 V or 48 V \pm 10% for one-way power.

▪ **Waveform deviation**

Waveform deviation shall not exceed 5%.

▪ **Rated frequency of the power and the maximum deviation**

Nominal value of alternating voltage power source frequency and the maximum deviation of these values are 50 ± 2 Hz.

22. Active power supply

Active power supply (consumption) of transmitter, including assistive devices, under the modulation with black and white picture and at the rated output power, must be indicated in the manufacturer's technical instructions.

23. The total power supply factor

The total power supply factor in terms of paragraph 22 of this article must be greater than 0.9.

24. Radio-frequency test points

Converter RF test points for measurement of the level of the output signal must be provided.

Measuring port loaded with 50 Ω at rated output power must not have higher levels of 20 dBm.

RF test point must have coaxial connectors type: BNC or N.

Oscillator must be of such construction that it allows the measurement of frequency and voltage of the oscillator.

25. Indicators

With built-in measuring instruments there must be a possibility to control:

- a. All major operating voltages of transistors and tubes;

- b. Voltage of the oscillator;
- c. Output levels;
- d. Input signal level.

When the converter is operating, thermostat must be initiated.
Provision under d. is not mandatory.

26. Measures

Dimensions (width, height and depth) of transmitter must be in accordance to the technical manual.

27. Mass

The mass of the transmitter must be in accordance to the technical manual.

Article 19

Section 24, 25, 26, 27, 28, 29, 30, 31, 32, 33 of Article 13 of the Regulation apply to TV converters.

Article 20

Special television converter features of are:

1. The amplitude/radio-frequency characteristic

The amplitude/radio-frequency characteristic must be within the limits shown in Figure 15 a and b.

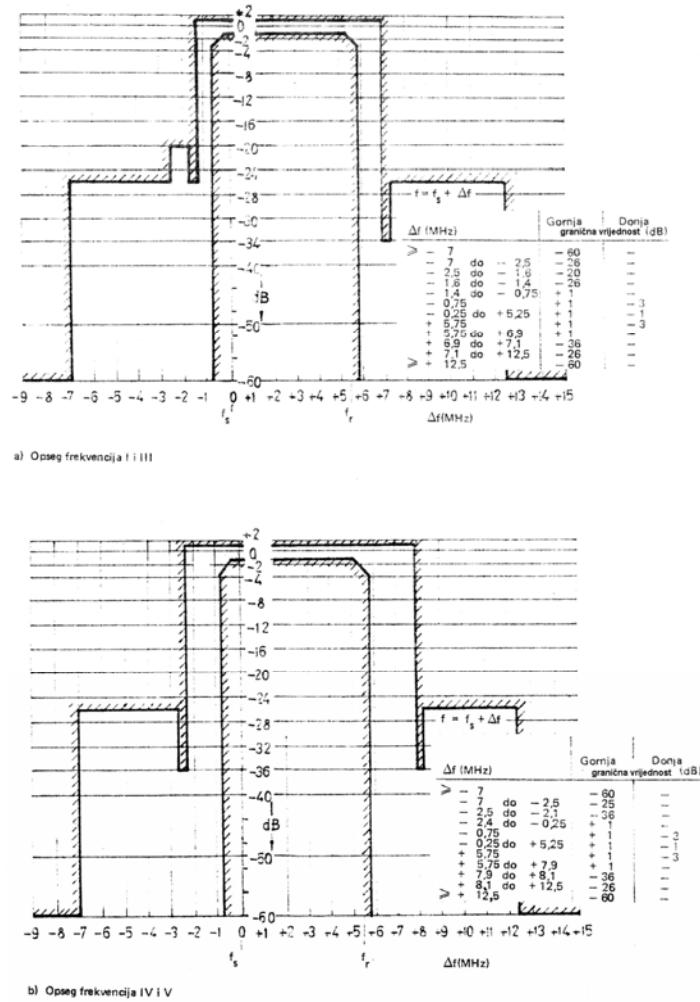

Figure 15: The amplitude/radio-frequency characteristic of television converter

2. Characteristics of group delay/radio-frequency

Differences in group delay shall not, in the frequency range from f to ± 5 MHz, exceed the value of ± 50 ns relative to the value of the image carrier.

In the frequency range from f to -0.75 MHz it is allowed to increase to ± 100 ns.

3. Automatic gain control (AGC) range

When changing the input voltage from -12 dB to $+14$ dB compared to 2 mV, output level shall not be changed by more than ± 1 dB.

The inverter shall be capable to turn off automatic gain control and to have the possibility of manual gain control.

4. Automatic gain control response time

When changing voltage ± 6 dB compared to 2 mV, response time shall not be longer than 1 s.

5. Internal unwanted signals at the entrance

Maximum power level of internally generated unwanted signals at the entrance to the converter must be:

- a. ≤ -51 dB μ V for bands $47-68$ MHz and $174-230$ MHz;
- b. ≤ -31 dB μ V for band $470-860$ MHz.

6. Noise factor

Converter noise factor must be:

- a. ≤ 20 μ V for bands $47-68$ MHz and $174-230$ MHz;
- b. ≤ 200 μ V for band $470-860$ MHz.

7. Intermodulation products within the channel

Intermodulation products in the frequency range from $f_s - 0.75$ MHz to $f_s + 5.75$ MHz must be suppressed for at least 54 dB.

8. Intermodulation products outside the output channel

Intermodulation products outside the output channel can not be greater than -55 dB.

9. Unwanted emissions in the presence of disturbing signals at the entrance

For the level of unwanted output signals of 60 dB below the reference output, the ratio of desired and undesired signals at the entrance shall not be less than 54 dB.

10. Feedback

Converter has to work with established properties when the attenuation between output and input is 50 dB.

11. Interference input signal

Interference input signal at intermediate frequency with intensity not greater than 1 V and at the symmetric frequency with intensity not larger than 0.1 V shall not produce a larger signal at the output compared to the signal which is obtained from the input signal of 0.5 mV.

12. Suppression of sound subcarrier interference signal

Suppression of sound subcarrier interference signal due to parasitic sound modulation in relation to the useful audio signal at frequency of 1 kHz, which gives the deviation of the carrier frequency of 30 kHz shall not be less than 46 dB.

13. The suppression of noise due to parasitic frequency modulation

The suppression of noise due to parasitic frequency modulation in relation to the useful audio-signal at frequency of 1 kHz, which gives the deviation of the carrier frequency of 30 kHz, shall not be less than 50 dB.

14. Variation in output power due to the image content

Variation in output power when changing from black to white image shall not exceed 1% .

15. Change in the level of suppression and white reference levels

Change in the level of suppression due to changes in image content shall not exceed 1%.

16. Luminance nonlinearity

Luminance nonlinearity shall not exceed 5%.

17. Differential gain

Differential gain related to the change in the amplitude of the auxiliary color carrier due to changes in the amplitude of the accompanying light signals must not exceed 3%.

18. Differential phase

Differential phase of reference color carrier shall not exceed 3°.

19. Signal-to-random noise ratio

Weighted signal-to-random noise ratio for lightning signal must be over 48 dB.

20. Signal-to-periodic noise ratio

Signal-to-periodic noise ratio and other undesirable single frequency components must be greater than 43 dB.

Article 21

During the disappearance of input signal, the converters output power must be at least 20 dB lower than the rated output power.

Article 22

If the disappearance of the input signal takes less than 2 min, the converter shall not be turned off.

Article 23

Setting the automatic activation and deactivation of the converter must be possible with any input voltage of the desired signal in the range from 0.5 mV to 10 mV.

Article 24

Converters for outdoor installation shall be in a case where it will be protected from rain, snow, condensation and insects.

Article 25

The noise generated by the television converter at a height of 1 m at a distance of 1 m from the front unit shall not exceed the value of 70 dB/B.

Article 26

UHF TV converters must have a connection for external oscillator for the excitation signal voltage level of 1 V.

Article 27

The converter must be staffed with a voltage stabilizer for all levels that are sensitive to change in line voltage supply.

Article 28

Before the first active element there must be an input filter with the characteristics given in Table 11.

f_0 + receiving frequency	Suppression in the range I i III	Suppression in the range IV i V
+ 14 MHz - 9 MHz	≥ 16 dB	
+ 16 MHz - 11 MHz		≥ 20 dB
+ 28 MHz - 23 MHz	≥ 36 dB	
+ 32 MHz - 27 MHz		≥ 42 dB

Table 10 - Characteristics of the input filter ahead of the first active element

Article 29

Minimum distance of the receiving and transmitting channel is one channel. It is possible to receive and transmit signal using channels on different frequency bands.

VI Determining the technical characteristics of television transmitters and converters

Article 30

Determining the technical characteristics of television transmitters and converters set forth in this ordinance shall be done by using measuring methods that are regulated by the international and national standards. Test signals, characteristics definitions and effective standards are given in Annex II to the Regulation.

VII Transitional and final provisions

Article 31

If television transmitters and converters from Article 1 of the Regulation do not fulfill the requirements of this ordinance, their technical characteristics must be brought into conformity with the ordinance under the provisions of the Law on Electronic Communications.

Article 32

On the effective date of this Regulation shall be supersede the "Regulation on technical and exploitation conditions under which they may use the broadcasting station for broadcasting television programs in the VHF bands I and II and UHF IV and V (" Official Gazette of RCG "No. 40 / 05, 42/06, 01/07, 16/07 and 45/07).

Article 33

This Regulation shall enter into force eight days after publication in the Official Gazette of Montenegro.

Agency for Electronic Communications and Postal Services

**PRESIDENT OF COUNCIL
Dr Šaleta Đurović**

Appendix I: Image carrier frequency shift

Oznaka	Frekvencijski pomak nosioca u djelovima f_H	Oznaka	Frekvencijski pomak nosioca u djelovima f_H
1P	+ 1/12	1M	- 1/12
2P	+ 2/12	2M	- 2/12
3P	+ 3/12	3M	- 3/12
4P	+ 4/12	4M	- 4/12
5P	+ 5/12	5M	- 5/12
6P	+ 6/12	6M	- 6/12
7P	+ 7/12	7M	- 7/12
8P	+ 8/12	8M	- 8/12
9P	+ 9/12	9M	- 9/12
10P	+ 10/12	10M	- 10/12
11P	+ 11/12	11M	- 11/12
12P	+ 12/12	12M	- 12/12
13P	+ 13/12	13M	- 13/12
14P	+ 14/12	14M	- 14/12
15P	+ 15/12	15M	- 15/12
16P	+ 16/12	16M	- 16/12
17P	+ 17/12	17M	- 17/12
18P	+ 18/12	18M	- 18/12
19P	+ 19/12	19M	- 19/12
20P	+ 20/12	20M	- 20/12

Table P. 1 - Image carrier frequency shift

Where otherwise provided sound carrier frequency is shifted for the same amount as the image carrier frequency.

Appendix II: Summary of test signals and definitions of characteristics that are measured by television transmitters

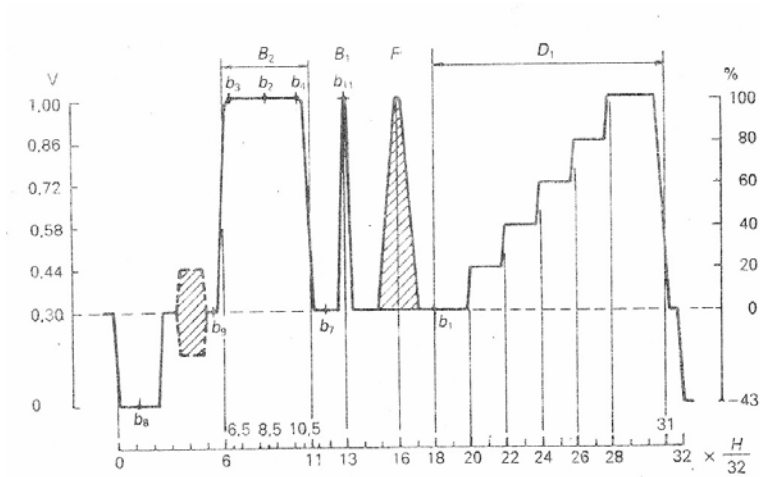

Image P. 1 - The test signal type I

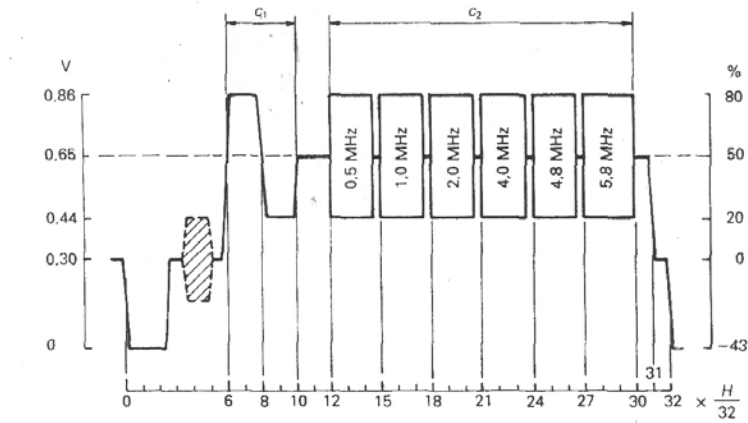

Image P. 2 - The test signal of type II

- B₂ - Luminance stripe (white reference level)
- B₁ - 2T sine-squared pulse
- F - Complex 20 T pulse
- D₁ - Luminance five-part stairs
- C₁ - Reference stripe
- C₂ - Sine-wave signals printed in gray

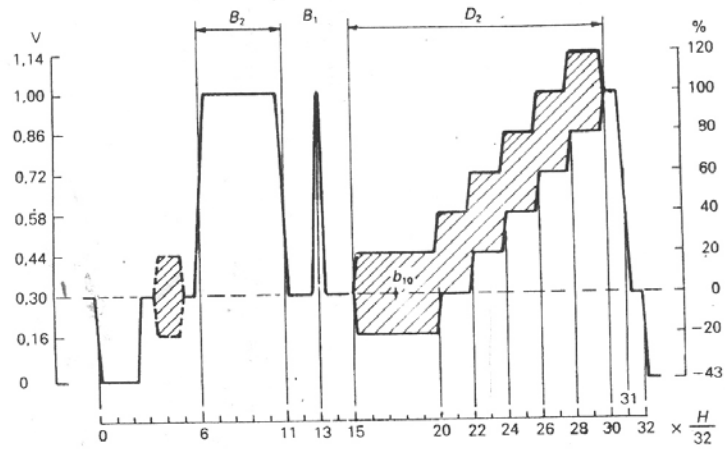

Image P. 3 - Test signal of type III

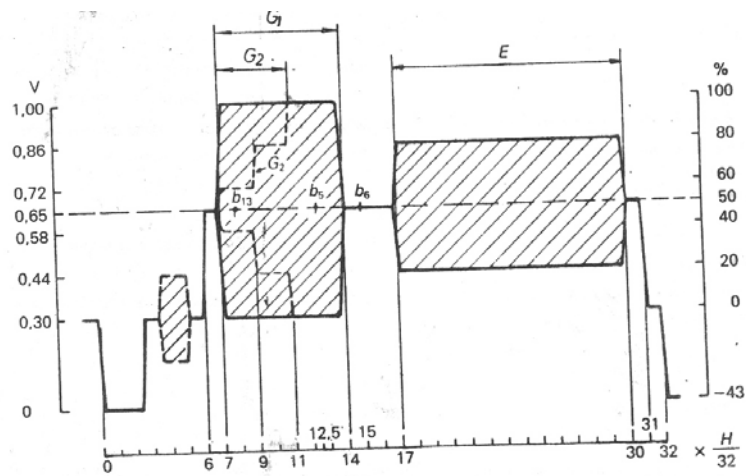

Image P. 4 - Test signal of type IV

- G1 - inserted chrominant stripe
- G2 - Embedded chrominant signal with three levels
- E - Inserted reference pilot carrier

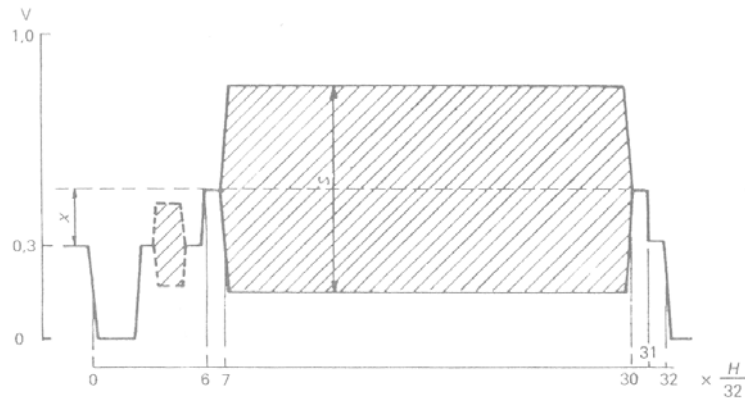

Image P. 5 - Test signal of type VII

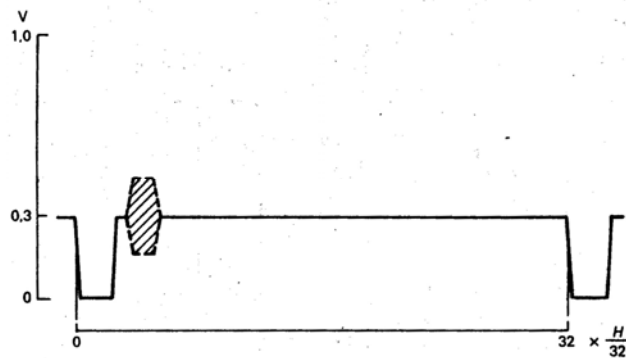

Image P. 6 - Test signal of type VIII

To insert the test signals lines 17, 330, 18 and 331 are used, and they must comply with requirements defined in the ordinance and the corresponding IEC standard.

Definitions of characteristics that are measured in TV transmitters

1. Error of amplitude of luminance stripe

Error of amplitude of luminance stripe is the difference between the actual amplitude of luminance stripe and its nominal value, expressed in percentages relative to the nominal value.

The sign of error is positive if the amplitude of the stripe is more than nominal value.

Signal that is used in the measurement is of the type I signal B₂.

2. Error of sync-pulse amplitude

Error of sync-pulse amplitude is the difference between the actual amplitude of the sync pulse and its actual value.

The sign is positive if the error of the sync pulse is greater than the nominal value.

Signal that is used in the measurement is of the type I.

3. Slope of luminance stripe

Slope of luminance stripe is the difference between the level of luminance stripe (area B₂) at b₃ point of demodulated test signal I, one microsecond after the point of the half of amplitude of the front edge and point b₄, one microsecond before the point of the nominal amplitude rear edge, expressed as a percentage of the amplitude of luminance stripe. The sign of error is positive if the level at point b₄ is greater than the level at point b₃.

4. Distortion of the baseline

Distortion of the baseline is expressed as the difference of the level of demodulated video signal at point b₇, one microsecond after the point of the half of amplitude of the descending edge luminentne line (area B₂) and the level at the reference point b₁, in percentage compared to the amplitude of luminance stripe. Sign of baseline distortion is positive if the level at point b₇ is higher than the level at point b₁.

5. Error ratio of 2T pulse and stripe

Error ratio of 2T pulse and stripe is the difference between 2T pulse amplitude (area B₁) and luminance stripe (area B₂) of demodulated test signal aI expressed as a percentage of the amplitude of lumineance stripes. 2T pulse amplitude is the difference between the level at point b₁₁ and reference point b₇.

The sign of error is positive if the amplitude of 2T pulse amplitude is greater than amplitude of luminance stripe.

6. 2T pulse shape distortion

2T pulse shape distortion shows the deviation from its ideal form. This type of distortion is defined by the factor K term, for which the values are outlined in the specification of the device. Test signal used is a signal of type I, the area B₁.

7. Inequality of chrominance / luminance gain

Inequality of chrominance / luminance gain is the difference between the peak amplitude of the chrominance signal in the area G₁ or G₂ of demodulated test signals of type IV and amplitud of reference luminance signal in percentage of the amplitude.

When using test signals of type IV, the amplitude of the reference luminance signal is equal to the amplitude of luminance strip in the area B₂ of test signal of type I.

8. Inequality of chrominance/luminance delay

Chrominance/luminance delay is the time difference in microseconds between luminance and chrominance components of complex 20T pulse of demodulated test signals of type I.

Inequality sign for delay is positive if the axis of symmetry of chrominance component is behind the axis of symmetry of luminance component.

9. Luminance nonlinearity

Luminance nonlinear change in amplitude as a function luminance signal amplitude.

10. Chrominance nonlinearity

Chrominance nonlinearity is the change in the amplitude of luminance signal in relation to luminance amplitude.

11. Differential gain

Differential gain is the maximum change in the amplitude of the auxiliary color carrier signal in relation to the amplitude of this signal at the level of suppression due to changes in the amplitude of associated luminance signal.

Measurements are performed on a chrominance stair signal in the D₂ test signal type III at different levels of luminance signal neglecting the highest level.

12. Differential phase

Differential phase is the maximum change of phase of chrominance auxiliary carrier in relation to the phase of the signal at the level of suppression due to changes in the amplitude of associated luminance signal.

Measurements are made with different luminance levels, with chrominance stair signal in the area D₂ of test signal type II, ignoring the highest level.

13. Chrominance/luminance mapping

Chrominance/luminance mapping is the change in amplitude of luminance signal in relation of amplitude of chrominance signal.

Chrominance/luminance mapping is measured in area G₁ or G₂ of test signal of type IV.

14. Random noise at the level of suppression

S/N ratio is the ratio expressed in decibels between the amplitude of luminance strip in area B₂ of test signal of type I and the effective value of weighted noise at the level of suppression.

When measuring the signal to noise ratio at the level of suppression test signal of type VIII is used.

15. Intermodulation within the range

Intermodulation within the range refers to transmitters and converters with a common picture and sound signal amplification.

Intermodulation frequency components produced within the band of video-frequencies due to intermodulation between the carrier of sound and carrier of image and the side components that corresponds to the additional color carrier is given by:

$$\Delta f - f_c$$

where:

Δf - the difference between the frequencies of sound carrier and picture carrier (5.5 MHz),

f_c - frequency of additional color carrier (4.43 MHz).

Intermodulation level within the band is measured in chrominance area of test signal type VII and is defined as the ratio between the amplitude of luminance strip in the area B₂ of tested signal type I and the peak value of intermodulation component at the frequency $\Delta f - f_c$, expressed in decibels.